

LONG SPAN CARPORTS

THE NEW STANDARD IN SOLAR CARPORTS

Quest Renewables' Long Span Carport is your solution for enabling the highest energy production on surface parking lots. The system generates more watts per acre where high power density is needed, reducing fixed cost per watt.

By re-imagining solar carports from a blank page, rather than adding solar to a regular carport, Quest's products are more aesthetically pleasing and are faster to build. Unlike traditional carports, 90% of the system's construction takes place on the ground. Structural assembly, module placement, and electrical/lighting scopes are all conducted on the ground before the trusses are lifted into place by crane. This process minimizes overhead work and maximizes worksite safety. A reduction in on-site time by half that of other carports reduces construction management costs, increases throughput, and limits disruption to parking lot operations.

The very same principles which enable the system's construction and structural efficiencies provide a sleek design that cannot be found anywhere else. The three-dimensional truss design uses lightweight materials which, when assembled, look modern, open, and artistic. Discover the new standard in parking lot aesthetics and energy production with Quest Renewables.

**HIGH DENSITY
INCREASES PROJECT SIZE**

**FASTER
CONSTRUCTION
IMPROVES PROJECT
ECONOMICS**

**PURPOSEFULLY
MODERN DESIGN
PRINCIPLES**

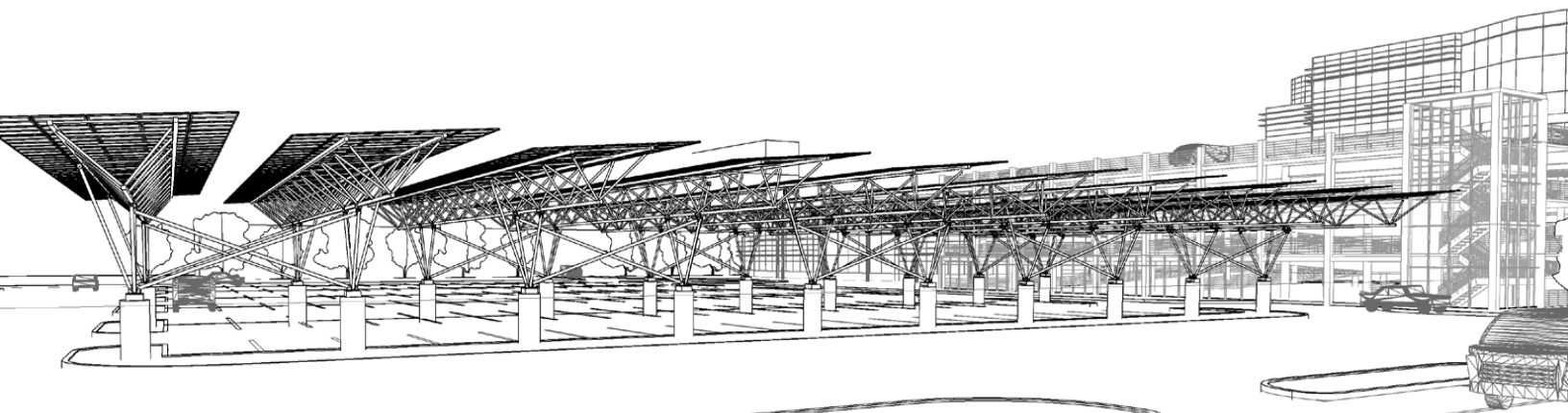

TECHNICAL SPECIFICATIONS

Length	100'-126'
Width	18'-24'
Max Height	16'-25' to top of modules
Clearance (min/max)	8'2"-16'
Span between foundations	50'-65'
Cantilever	10'-30'
DC Capacity	varies by module
Wind Load Capacity	designed and tested for 150 mph winds
Snow Load Capacity	designed and tested for 60 psf snow
Standard steel coating	G90

TESTING/CERTIFICATIONS

Wind tunnel testing	CPP
Installation time and motion testing	Yes
UL 2703 Bonding and Grounding	ETL Intertek

ENHANCEMENTS

Snow management
Rain water collection
Inverter mounting
Lighting
Battery storage
Marine environments

INSTALLATION SERVICES

Structural plansets
Staging and pick plans
Stamping services in 50 states
Construction training and management

FEATURES AND BENEFITS

Maximum capacity	allows panel coverage over drive lanes for maximum density
Speed	on ground assembly drives efficiency across the Balance of System
Safety	90% on the ground assembly
Labor efficiency	up to 50% less labor hours

MISC

Material lead time	12 weeks
Standard Warranty	10-year
kW/Acre	varies by module/design

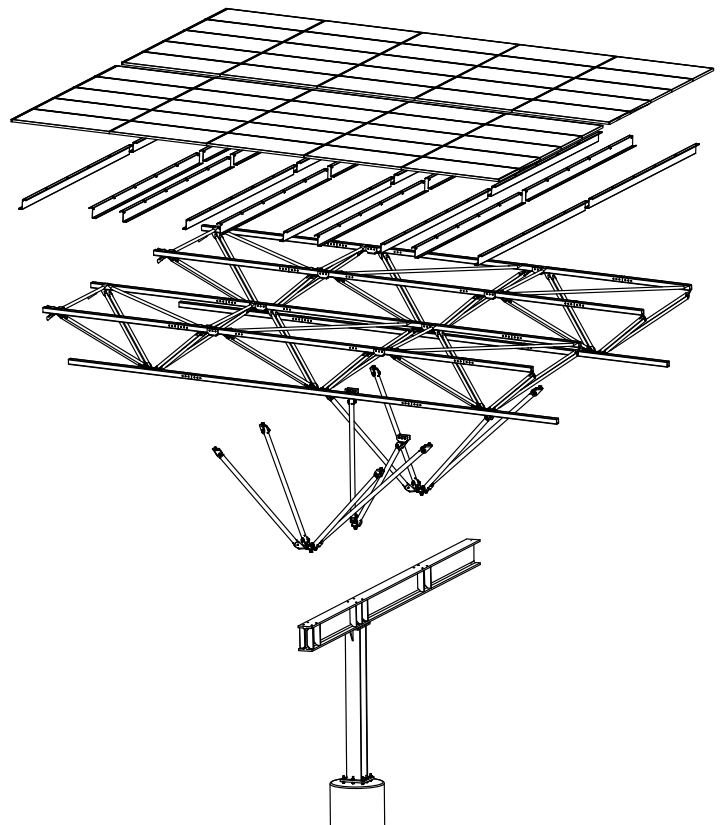

The details contained in this document are estimates based on our experience. If you have a specific contract in mind, please contact us for customized technical specifications.

Quest Renewables partners with our customers to create highly aesthetic solar racking solutions that maximize project performance, eliminate waste, and allow entry into new markets.

Our commitment to optimizing the total installation process results in more satisfied developers, contractors, and site owners.

Made in the USA

404.536.5787

info@questrenewables.com

www.questrenewables.com



[@questrenewables](https://www.instagram.com/questrenewables)

